

{ Vibrating Screens }

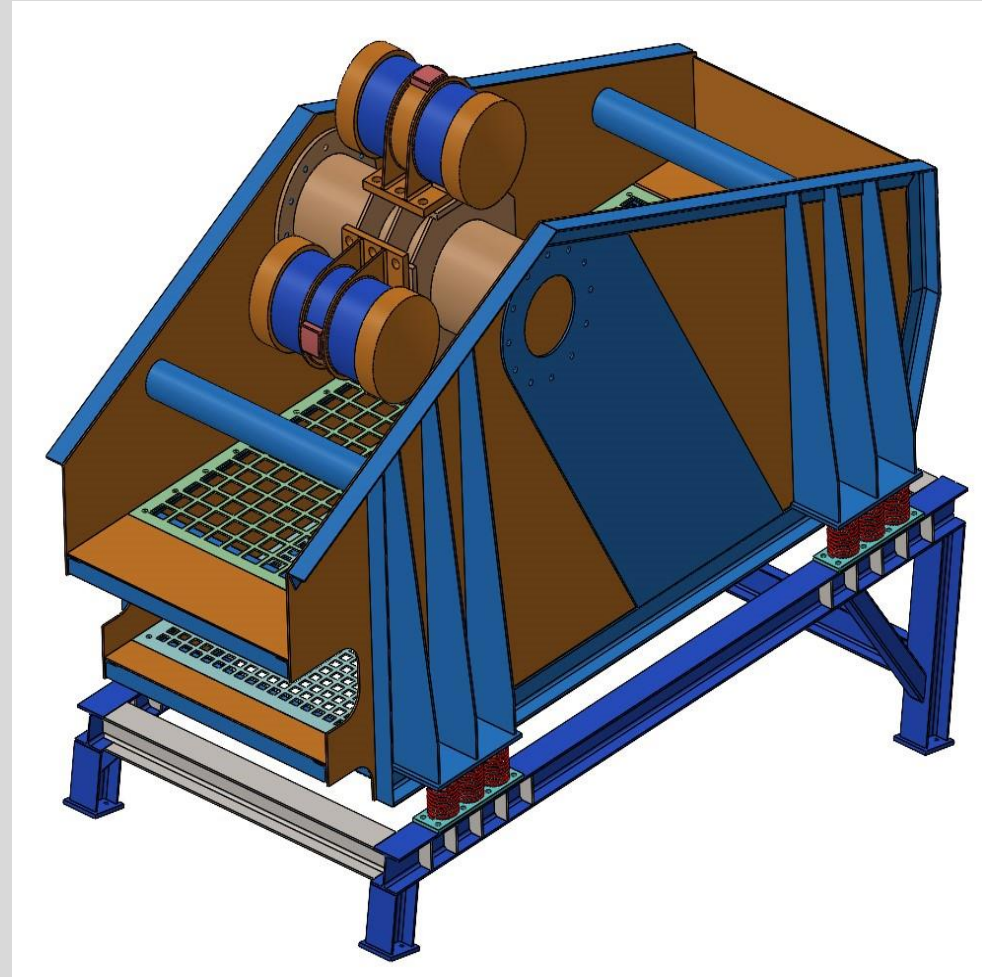

- Vibrating screens are becoming more widely used across various industries because they allow for strict size-control and efficient separation in material sorting.
- Screens are available in a single motor design for elliptical motion or a dual motor design for linear screening and can work with either a horizontal or incline set-up. Each vibration method ensures the particles passing along the screen, if small enough, will have the opportunity to fall through the screen mesh between the start and end of the deck. Each style comes in standard sizes, but can be customized with different deck systems, including wire mesh, steel, rod decks or polyurethane panels.
- Screen capacity and longevity can depend on screen use, cleanliness, and the aggregate being screened.
- NDESCO provide several types of vibrating screens in many industries (Sugar, Sand, Sand...etc.).



نديسكو للتصميم والحلول الهندسية (ش.ذ.م.م)

Name You can trust

Head Office

► 16 Zohoor El Maadi City (Badr towers) beside Carrefour

Tele fax +202 23104241 Tel.: +202 23104243

Factory:

► Industrial Zone, Bayed El Arab, Bani Suief, Egypt